



Technical Monograph  
Consensus® Hip System

# Table of Contents

<b>Design Rational.....</b>	<b>1</b>
Introduction.....	1
Femoral Geometry.....	1
Overall Sizing.....	1
Neck Angle and Length, Collar Angle, and Head Offsets.....	2
Proximal Geometry.....	3
Distal Geometry.....	4
Modular Taper.....	5
Materials.....	5
Forged Cobalt-Chrome for Cemented Stem.....	5
Forged Titanium for Non-Cemented Stems.....	5
<b>Product Descriptions.....</b>	<b>6</b>
Femoral Stems.....	6
CoCr Collared, Cemented Femoral Stem.....	6
Modular Distal Centralizer and Proximal Spacer.....	6
Ti Collarless Press Fit Stem.....	8
Ti Porous Coated, Collarless and Collared, Press Fit Femoral Stem.....	9
Porous Coating.....	10
Femoral Heads.....	11
Acetabular Components.....	12
Metal Back Acetabular Shell.....	12
Acetabular Insert.....	14
PMMA Cement Pods.....	15
Cancellous Bone Screw.....	15
<b>References.....</b>	<b>16</b>

# Design Rational

## Introduction

The design philosophy of the Consensus® system is to restore the original anatomic position of the femoral shaft to the acetabulum. The stem is designed to facilitate restoration of a wide variety of femoral geometries as indicated in roentgenographic-cadaveric studies.<sup>1,2</sup> The position and angle of the femoral stem taper with respect to the femoral shaft and lesser trochanter is set at the neutral average of all femoral geometry.

## Femoral Geometry

### Overall Sizing

The system provides **7 sizes** of cemented stems to cover a range of **prepared canal diameters from 10mm to 16mm** and **8 press fit stems in diameters of 8mm to 15mm**. The variance in stem sizes is roughly proportional and centered on the average dimensions of a mid-size stem. These sizes have been designed to cover a wide range of anatomic variations while minimizing the inventory required. Stem length is based on anatomic averages of the distance from the osteotomy level to the canal isthmus for each canal diameter. The proximal A/P widths are based on endosteal dimensions at the osteotomy level.<sup>2</sup>

The same proximal stem geometries are utilized for both press fit and cemented designs. In the cemented version, the distal stem is tapered. The cemented broaches increase the femoral canal to allow for a **2mm cement mantle**.

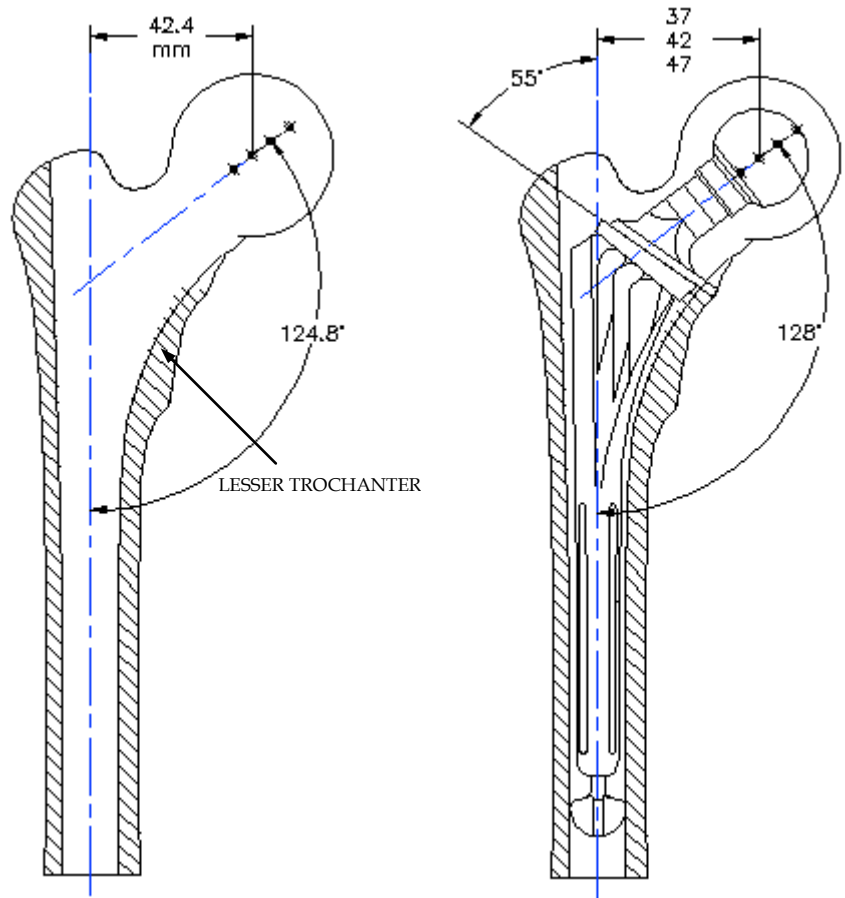

Fig. 1 Neck length options in comparison to the average anatomical femur.

## Neck Angle and Length, Collar Angle, and Head Offsets

The neck of the femur has been reported to average  $124.8^{\circ}$ . The neck angle selected for the Consensus stem is  $128^{\circ}$  to replicate the natural anatomic angle of the femur among all stem offsets as indicated in **Figure 1**.

The lateral offsets provided by the Consensus system cover wide anatomic variations using three basic offsets in combination with four neck lengths, -5mm, neutral, +5mm, and +10mm. Figure 1 shows how the system is centered on the average anatomic value and allows variations to cover most of the anatomic range.

As shown in **Figure 2**, stem loading will provide compressive force on the proximal-medial and distal-lateral canal cement mantle. Femoral loading will provide additional medial force in non-cemented applications by load distribution of the collar onto the resected calcar.

The collar angle is set at  $55^{\circ}$  to be approximately normal to the average  $10^{\circ}$  to  $30^{\circ}$  hip loading angle. No distinct performance change has been clinically noted due to variations in the angle of the collar.<sup>3</sup>

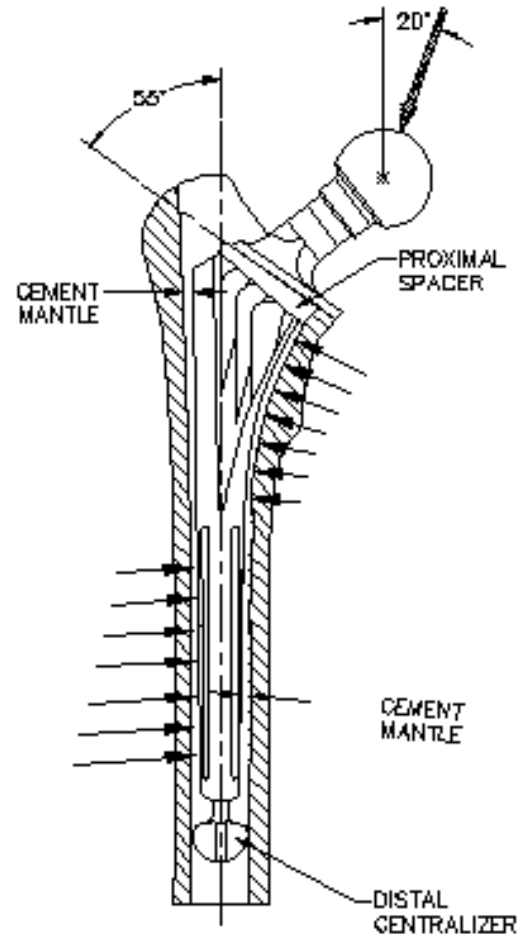

*Fig. 2 Femoral stem loading of the medial-proximal and lateral-distal femur.*

## Proximal Geometry

Limiting the possibility of implant subsidence, loosening, and micromotion are the key elements in stem implant longevity. The Consensus stem incorporates a compound proximal wedge (CPW) design. As shown in Figure 3, the stem is tapered in the sagittal, coronal, and transverse plane. The effect of the CPW design improves load transfer both the cementless and cemented stem applications.

As illustrated in Figure 4, the medial face of the stem is slightly curved with large corner radii blending into the anterior and posterior sides. The lateral face is flat with large corner radii blending into the anterior and posterior sides. These corner radii help evenly distribute the cement mantle stress by eliminating stress-concentrating corners.

To enhance compressive load transfer from prosthesis to the femoral shaft, normalization steps have been added to the cemented stem and press fit non-porous stem. These steps increase the projected area of the stem in the transverse view.

In the coronal plane view, the stem flare and medial radius of the proximal bodies are designed to fit the femoral endosteal anatomies presenting low flare indices as reported in Noble's anthropometric study.<sup>2</sup>

The Consensus stems incorporate a proximal drive hole that allows the stem to be held with the stem holding instrument and seated in the femoral cavity with accuracy.

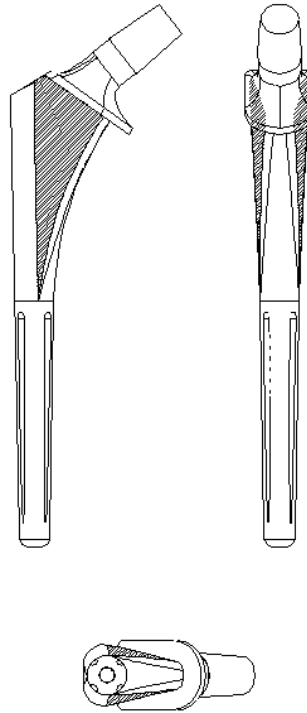

*Fig. 3 Compound Proximal Wedge design provides positive initial fixation and long-term stability.*

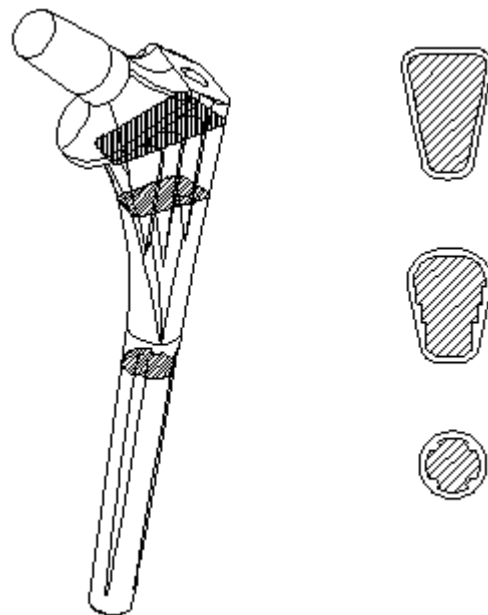

*Fig. 4 Transverse section geometry optimizes cement stress levels and implant longevity.*

## Distal Geometry

### *Non-Cemented Stems*

Distal fit has been reported to have a strong relationship with implant stability and minimizing micro-motion and thigh pain. The distal femoral canal must be prepared and accurately fit with a matching distal stem to optimally distribute the stem loads to the endosteum. An accurately fitted distal stem will also enhance initial fixation by minimization of stem toggle.

The Consensus non-cemented stems feature a full cylindrical stem for simplification of canal preparation, control of distal fill and optimization of proximal fit. With cylindrical distal reaming and a cylindrical distal stem, the proximal cavity can be broached to the size and position that best fits the proximal bone. The broach is guided, but not limited by the distal stem. The alternative of reaming a tapered distal canal will result in either the implant seating proximally and leaving a gap distally or seating distally first and not achieving the appropriate proximal press fit. With a “slip-fit” distally, the proximal CPW geometry is allowed to find its most stable position by sliding distally within the cylindrical hole with a line to line fit.

Linear flutes are incorporated into the distal diameter of the Consensus stems. These flutes can act as vents to minimize pressurization of the femoral canal that could lead to fat or air emboli during stem insertion. These grooves also reduce the stiffness of the stem while still maintaining wall to wall contact with the endosteum.

### *Cemented Stems*

In the cemented stems, the distal stem is tapered to provide compressive loading of the distal cement. This taper design also allows the system to be used in smaller femoral canals while still allowing for an adequate cement mantle.

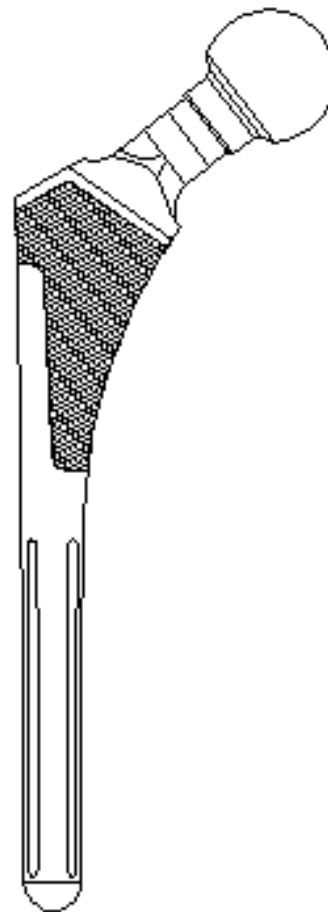

*Fig. 5 Linear flutes reduce stem stiffness, facilitate stem insertion and minimize distal canal pressurization.*

## **Modular Taper**

The use of modular femoral heads greatly increases the physician's intraoperative options while minimizing inventory. The use of modular heads has become the standard in hip stem design due to the high reliability and performance offered by modular tapers. Ceramic heads can reduce the rate of polyethylene wear by a factor of 2. However, a special taper is required to accommodate the material characteristics of ceramic heads. A standard has emerged for a 12/14 taper which is certified by the ceramic head manufacturers.

## ***Materials***

The Consensus stems are available in either forged cobalt chrome or forged titanium alloy material. These materials are most often specified for femoral hip stems based on their excellent biocompatibility and high strength.

### **Forged Cobalt-Chrome for Cemented Stem**

Cobalt-Chrome (CoCr) alloy materials provide an optimal combination of high strength, stiffness, hardness and excellent biocompatibility for use in a cemented stem application. To minimize stress on the bone cement, a stem with relatively high material stiffness is indicated. The net result is that higher stem stiffness prevents cement fatigue failures and thus prolongs implant life. Forged CoCr is selected for its optimal fatigue strength and absence of fine material imperfections sometimes found in cast CoCr.

### **Forged Titanium for Non-Cemented Stems**

Titanium (Ti) provides the lowest stiffness among currently used hip stem implant materials. The flexibility of stems has been shown to be inversely proportional to the level of thigh pain.<sup>5</sup> The low modulus of elasticity of titanium effectively minimizes thigh pain while providing excellent biocompatibility and strength. The lower stiffness of Ti allows the stem to flex with the femoral shaft during normal load cycles. Forged Ti is selected for its higher properties of fatigue strength and absence of fine material defects over cast Ti.

# Product Descriptions

## *Femoral Stems*

### **CoCr Collared, Cemented Femoral Stem**

The Consensus Cobalt-Chrome stem, shown in Figure 7, offers the features most demanded in a cemented femoral stem prosthesis. The stem combines a compound proximal wedge body, cement normalization steps, wrap around collar, grit blast proximal body, distal grooves and a tapered distal stem.

In combination with cement normalization steps on the stem, the broached cavity is wedge shaped to closely match the anatomic proximal endosteum. In a stem without normalizing steps, shear stress may cause cohesive failure at the implant-cement interface after cyclic fatigue loading. The combination of wedge body and normalization steps allows the cement to evenly transmit loads to the endosteal walls while maintaining compressive loads within the cement mantle. The transverse section shape of the compound proximal wedge has also been shown to minimize tensile loading of the cement on the lateral side of the stem.<sup>6</sup>

The collar is a wrap around configuration incorporating a wide side flange. In cemented applications, the wrap around design promotes optimal cement compression, improved stress transfer to the calcar region and control of subsidence.<sup>7</sup> To ensure accurate fit of the proximal stem and seating of the collar, a calcar planer, guided by the broach, is used to finish preparation of the proximal femur.

The Consensus CoCr cemented stem is provided with a rough grit-blasted proximal body to maximize the adhesion between the implant and the cement.

### **Modular Distal Centralizer and Proximal Spacer**

The cemented stem is designed to be used with PMMA modular proximal cement spacers and distal centralizers. The spacers will ensure that the stem is fixed with a consistent thickness cement mantle. The cement mantle is slightly less than 2mm distally, with a gradual taper to 2mm proximally. Another feature of the modular proximal spacer is that it may be removed intraoperatively at the surgeons' option.

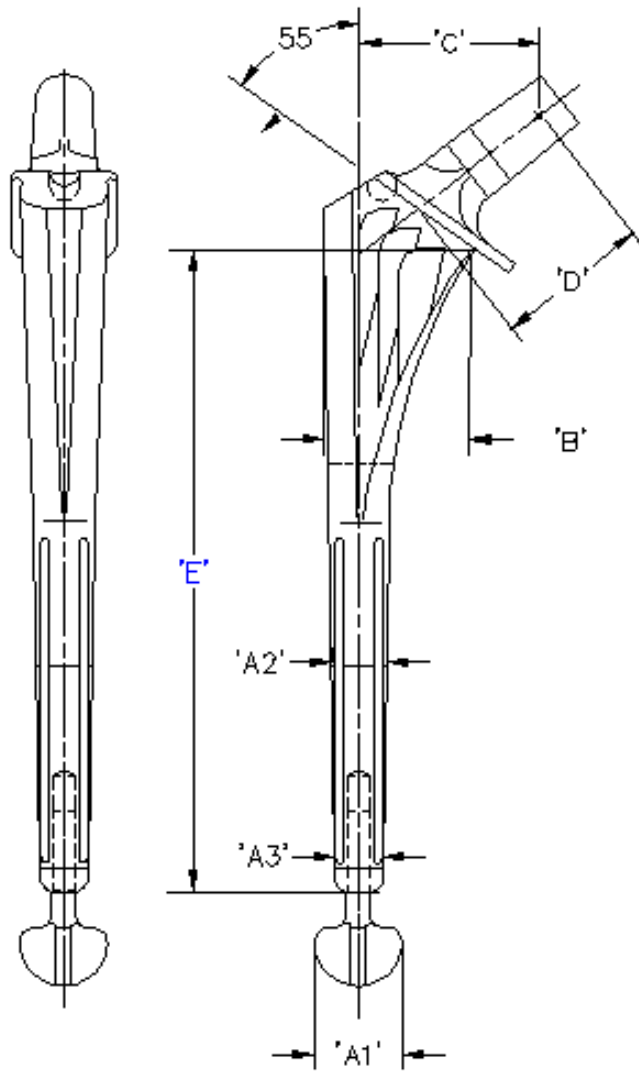

Base Material	Forged CoCr per ASTM
F799	
Base Sizes	7 Bilateral Sizes
Neck Angle	128°
Collar Angle	55°
Proximal Finish	Grit Blast Proximal
Distal Finish	Bead Blast Distal
Taper	12/14 Standard

Fig. 7 Consensus CoCr Collared, Cemented Femoral Stem

	SIZE 10	SIZE 11	SIZE 12	SIZE 13	SIZE 14	SIZE 15	SIZE 16
Distal Centralizer Diameter - 'A1'	10mm	11mm	12mm	13mm	14mm	15mm	16mm
Cylindrical Stem Diameter - 'A2'	8mm	9mm	10mm	11mm	12mm	13mm	14mm
Distal Stem Diameter - 'A3'	6.5mm	7.5mm	8.3mm	9.2mm	10.2mm	11.0mm	11.8mm
M/L Width at Collar B	24mm	27mm	27mm	29mm	33mm	34mm	36mm
Neutral Head Offset C	37mm	37mm	37mm	37mm	42mm	42mm	42mm
Neutral Neck Length D	34mm	34mm	34mm	33mm	37mm	37mm	35mm
Stem Length E	108mm	124mm	124mm	133mm	141mm	151mm	160mm

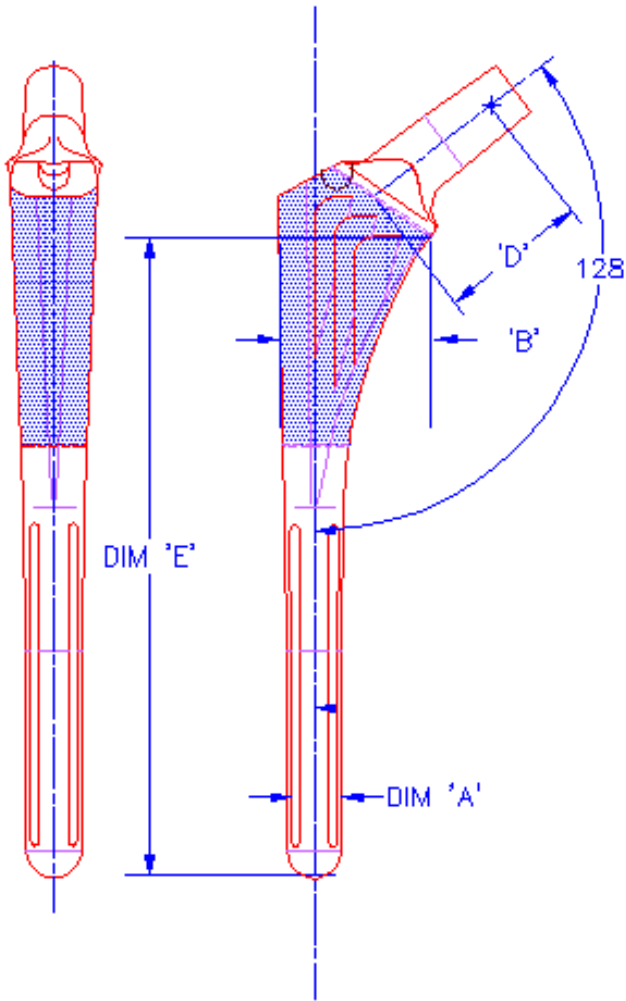

### Ti Collarless Press Fit Stem

The nonporous press fit titanium stem, shown in **Figure 8**, is designed with a 1.0mm press fit proximally between the broach and stem and a distal line-to-line fill. The proximal body has normalization steps with a grit blasted finish for optimal osteointegration. As bone apposition occurs, these steps will help minimize migration and subsidence of the prosthesis by providing compressive load transfer locations. This stem is also designed with distal anti-rotation and insertion venting flutes along the cylindrical distal body.

### HA Coated, Ti Nonporous, Press Fit Femoral Stem

The consensus HA/Ti collarless press fit stem is provided with a 50 micron<sup>8</sup> thick coating of high purity hydroxylapatite to enhance bone apposition to the underlying grit blasted surface. The stem design incorporates a compound proximal wedge, normalization steps, cylindrical distal diameter, and distal flutes. The design is geometrically similar to the Ti, press fit stem shown in **Figure 8**.

Fig. 8 Consensus Ti Collarless Press Fit Stem and Collarless Press Fit HA Stem

Base Material	Forged Ti 6 Al-4V per ASTM F620
Base Sizes	8 Sizes
Neck Angle	128°
Distal Finish	Bead Blast
Proximal Finish	Grit Blast on Press Fit Stem
HA Coating	HA over Grit Blast on HA Stem
Taper	12/14 Standard

	SIZE 8	SIZE 9	SIZE 10	SIZE 11	SIZE 12	SIZE 13	SIZE 14	SIZE 15
Distal Stem Diameter A	8mm	9mm	10mm	11mm	12mm	13mm	14mm	15mm
M/L Width at Collar B	24mm	26mm	27mm	29mm	33mm	34mm	36mm	39mm
Neutral Head Offset C	37mm	37mm	37mm	37mm	42mm	42mm	42mm	47mm
Neutral Neck Length D	34mm	34mm	34mm	33mm	37mm	37mm	35mm	41mm
Stem Length E	108mm	114mm	124mm	133mm	141mm	151mm	160mm	169mm

## Ti Porous Coated, Collarless and Collared, Press Fit Femoral Stem

The Consensus press fit porous coated Ti stems, shown in **Figure 9**, are offered in collarless and collarless designs. Both designs incorporate a compound proximal wedge in the porous region with a 1.0mm proximal press fit between the broach and implant. Nonporous areas, including the distal stem, have a smooth finish to minimize any wear due to normal micro-motion between the bone and stem.

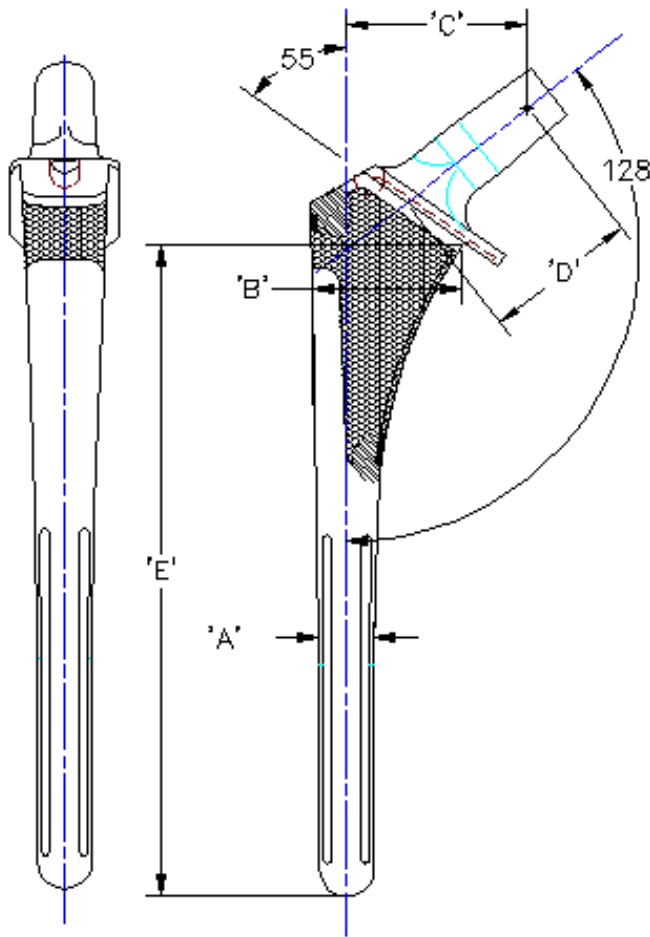

Base Material	Forged Ti 6 Al-4V per ASTM F620
Base Sizes	8 Bilateral Sizes
Neck Angle	128°
Collar Angle	55°
Distal Finish	Smooth
Proximal Finish	Porous Coat
Taper	12/14 Standard
Porous Coating	214 micron pore, -25+35 mesh, CP Ti per ASTM F67

Fig. 9 Consensus Ti, Porous Coated, Press Fit, Femoral Stem

	SIZE 8	SIZE 9	SIZE 10	SIZE 11	SIZE 12	SIZE 13	SIZE 14	SIZE 15
Distal Stem Diameter A	8mm	9mm	10mm	11mm	12mm	13mm	14mm	15mm
M/L Width at Collar B	24mm	26mm	27mm	29mm	33mm	34mm	36mm	39mm
Neutral Head Offset C	37mm	37mm	37mm	37mm	42mm	42mm	42mm	47mm
Neutral Neck Length D	34mm	34mm	34mm	33mm	37mm	37mm	35mm	41mm
Stem Length E	108mm	114mm	124mm	133mm	141mm	151mm	160mm	169mm

## **Porous Coating**

The porous coating design incorporates a full circumferential commercially pure Ti porous coating on the proximal body to provide optimal fixation. The circumferential coating, after bone ingrowth, creates a seal that has been shown to minimize migration of polyethylene particles into the femoral canal.<sup>4</sup> All but the top quarter area of the lateral face is uncoated to allow relative motion between the stem and femur, thus preventing stress shielding. This also reduces stress levels in the lateral side of the stem where high tensile loading occurs.

On the collared, porous stem, the collar is porous coated on the inferior side to improve fixation by allowing bone ingrowth at the calcar. The collar is reported to prevent subsidence and bone resorption by recreating loads and stresses in the calcar; more closely resembling those found in the natural anatomy.

## *Femoral Heads*

The Consensus Hip System provides physician choices for selection of femoral heads. The femoral heads are available in cobalt chrome as well as either Zirconia or Alumina ceramic. The designs incorporate a 28mm diameter head size that has been shown to provide the best balance between optimizing wear and compressive stress distribution of the acetabular cup.<sup>9</sup> 22.25mm Heads are also available for use with small Acetabular and Bipolar components. The heads are ultra precision manufactured to high sphericity and surface finish to minimize wear. The range of neck sizes are shown in Figure 10.

Heads	Offsets									
	-5mm	-3.5mm	-3mm	+0mm	+3mm	+3.5mm	+5mm	+6mm	+10mm	
CoCr	22mm	*	*	√	√	√	*	*	√	*
	28mm	√	*	*	√	*	*	√	*	√
	32mm	√	*	*	√	*	*	√	*	√
Zirconia	28mm	*	√	*	√	*	*	√	*	*
	32mm	*	√	*	√	*	*	√	*	*
Alumina	28mm	*	√	*	√	*	√	*	*	*

\* = N/A

*Figure 10. The Consensus System offers several neck lengths in a choice of materials.*

## Acetabular Components

The Consensus Hip System offers a universal metal backed acetabular component design. The shell may be either press fit or cemented. When cementing, cement pods (spacers) are provided to ensure an even cement mantle. Two modular UHMWPE acetabular insert designs are provided, with either a 20° hood or a flat inferior face. The shell may be used with or without bone screws, and a no-hole shell is available for press-fit application.

### Metal Back Acetabular Shell

Fourteen sizes of Acetabular shells ranging from 42mm to 68mm diameter in 2mm increments are offered. Screw holes are provided for enhanced component fixation. Holes are located in the regions of most probable use<sup>10</sup>. As shown in figure 11, a cluster of three holes are placed superiorly with one hole located anterior-inferior and one hole located posterior and inferior. **Extreme caution should be used when placing screws inferiorly to avoid damaging critical vascular structures.** The shell may be used without screws by placing the screw hole cluster inferiorly to provide continuous porous area support in the superior region of the acetabulum. This shell position reduces the incidence of polyethylene cold flow by elimination screw holes in the loaded region of the shell cavity. The no-hole acetabular shell can be used for press-fit application, significantly reducing the potential for cold-flow, back side wear and wear debris transport by eliminating the screw holes.

Scallops on the interior of the peripheral rim of the shell provide rotational stability of the insert while the undercut groove provides positive retention of the insert. A hole is provided in the top of the dome to provide visualization of seating during impaction.

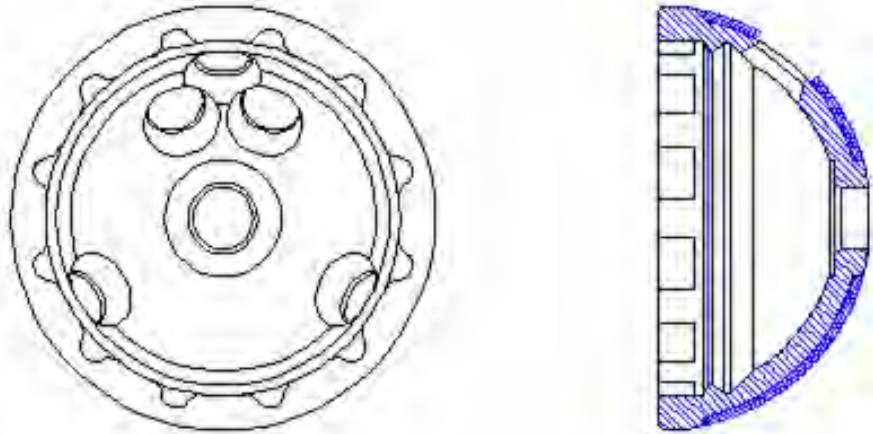

Figure 11. Acetabular Shell Component

Base Material	Forged Ti 6Al-4V per ASTM F620
Base Sizes	14 sizes 42mm to 68mm
Porous Coating	214 micron pore, -25+35 mesh CP Ti per ASTM F67

## Acetabular Insert

The acetabular insert is designed to be intraoperatively assembled after fixation of the acetabular shell. The 46-68mm inserts will receive a 28mm femoral head and provide up to 110° ROM in the medial-lateral plane. The acetabular insert is offered in a flat design as well as a hooded design. The hooded acetabular insert provides additional lateral coverage to increase the stability of the reconstructed hip. An x-ray wire marker for post-operative evaluation of cup position is also included in the hooded version. The polyethylene material used in the Consensus system are continuous-compression-molding-sintered (ram compression extruded) from Hoechst Celanese, Hostalen® GUR 415 resin. GUR 415 is the purest, highest molecular weight polyethylene used in the orthopedic industry today<sup>11</sup>. The final ram compression molded form of polyethylene used exceeds<sup>12,13</sup> the standards set in ASTM F648-84 including fusion defects<sup>14</sup>. This is done through strict statistical process controls (SPC) and supplemental quality control methods.

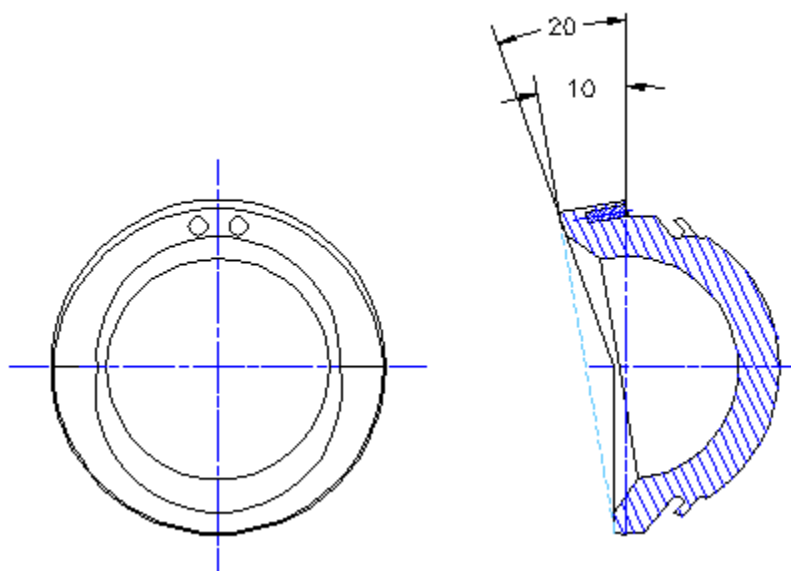

Figure 12 Acetabular Insert Component

Base Material	Ram molded UHMWPE per ASTM F-648
Base Sizes	14 sizes to fit 42mm to 68mm diameter shells
Head Size	32 mm (52-68mm shells), 28mm (46-68mm shells) and 22.25mm( 42 & 44mm shells)
Hood Options	20° or none

## PMMA Cement Pods

Cemented use of the porous coated metal back acetabular component may be accomplished by use of modular cement pods. An even cement mantle of 2mm is provided by installing five cement pods into the available screw holes. Intraoperative installation is accomplished by pressing the pods into place with firm finger pressure.

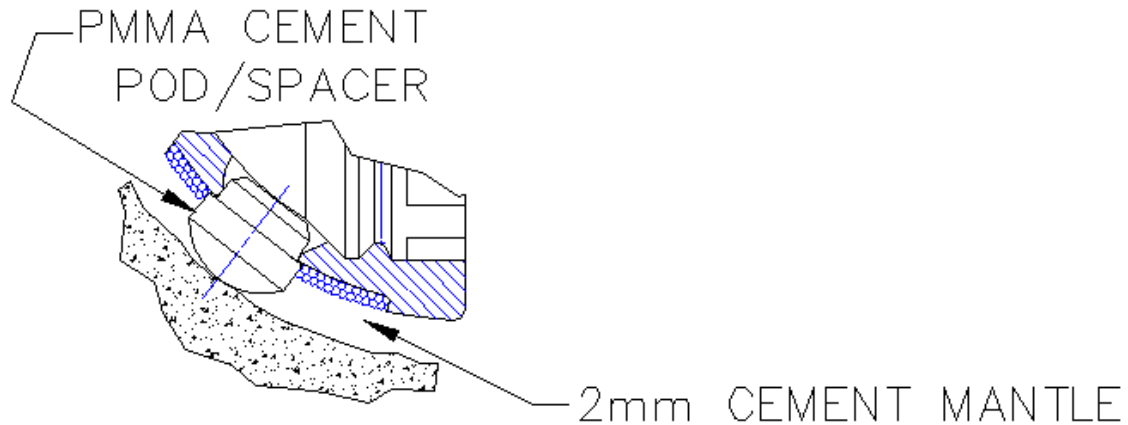

Figure 13 Acetabular Cement Pod

## Cancellous Bone Screw

Cancellous bone screws, as shown in Figure 14, are provided in the Consensus system to optimize initial fixation of the acetabular component.

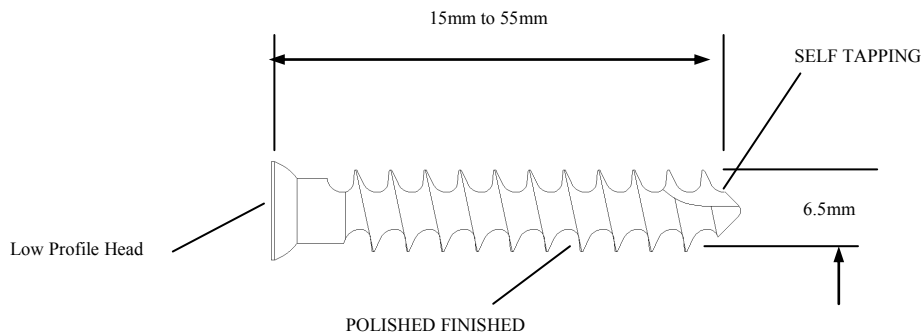

Figure 14. Cancellous Bone Screw Design Features

Type	Cancellous
Diameter	6.5 mm dia
Lengths	25 mm to 55 mm in 5 mm increments
Material	Wrought Ti 6AL-4V per ASTM F-136 and
Drive hex	3.5 mm per ISO 5835

# References

- <sup>1</sup> **Noble, P.C.; Lindahl, L.J.; Jay, J.L.; Davidson, J.; and Tullos, H.S.:** Femoral Anatomy and the Design of Total Hip Replacements. *Proceedings of the 32nd Annual Orth. Res. Society Meeting*, Feb 17-20, 1986
- <sup>2</sup> **Noble, P.C.; Alexander, J.W.; Lindahl, L.J.; Yew, D.T.; Grandberry, W.M.; and Tullos, H.S.:** The anatomic basis of femoral component design. *Clin. Orthop.*, 235: 148-165, 1988
- <sup>3</sup> **Markoff, K.L.:** The HIP, Proceedings of the Eighth Open Scientific Meeting of the Hip Society. In Vitro and Technical Considerations in Femoral Component Insertion., C.V. Mosby, St. Louis, pp. 135, 1980
- <sup>4</sup> **Friedman, R.; Black, J.; Galante, J.O.; Jacobs, J.J.; Inner, H.B.:** Current Concepts in Orthopedic Biomaterials and Implant Fixation. *J.Bone and Joint Surg.*, 75-A: 1088, 1993
- <sup>5</sup> **Franks, E.; Mont, M.A.; Marr, D.C.; Jones, L.C.; and Hungerford, D.S.:** Thigh Pain as Related to Bending Rigidity of the Femoral Prosthesis and Bone. *Trans. Orthop. Res. Soc. Meeting*, 17:296, 1992
- <sup>6</sup> **Crowninshield, R.D.; Brand, R.A.; Johnston, R.C.; Milroy, J.C.:** The Effect of Femoral Stem Cross Sectional Geometry on Cement Stresses in Total Hip Reconstruction. *Clin. Orthop.*, 146:71-77, 1980
- <sup>7</sup> **Crowninshield, R.D.; Brand, R.A.; Johnston, R.C.; Pedersen D.R.:** An Analysis of Collar Function and the Use of Titanium in Femoral Prostheses. *Clin. Orthop.*, 158:270-277, 1981
- <sup>8</sup> **Kester, M.A.; Manley, M.T.; Taylor, S.K.; Cohen, R.C.:** Influence of Thickness on the Mechanical Properties and Bond Strength of HA Coatings Applied to Orthopedic Implants. *Proceedings of the 37th Annual Orth. Res. Society*, Mar 4-7, 1991
- <sup>9</sup> **Livermore, J.; Ilstrup, D.; Morrey, B.F.:** Effect of Femoral Head Size on Wear of the Polyethylene Acetabular Component, *J. Bone and Joint Surg.*, 72-A:518-528, April 1990
- <sup>10</sup> **R.C. Wasielewski, L.A. Cooperstein, M.P. Kruger, H.E. Rubash;** Acetabular Anatomy and the Transacetabular Fixation of Screws in Total Hip Arthroplasty, *J. of Bone and Joint Surg.* 72-A:501-508, April 1990
- <sup>11</sup> **S. Li, A.H. Burstein;** Current Concept Review, Ultra-High Molecular Weight Polyethylene, *J. of Bone and Joint Surgery*, V. 76-A, pp 1080-1090, 1994
- <sup>12</sup> Issues in UHMWPE February 1994, Westlake Plastics Co., Medical Plastics Division, Lenni, PA, ©1994 (Hostalen GUR is a registered trademark of Hoechst AG)
- <sup>13</sup> **J.S. Serwatka, J.J. Ploskonka;** A Statistical Study of Ram Extruded Lennite© Ultra-High-Molecular-Weight-Polyethylene, *The 20th Annual Meeting of the Society for Biomaterials*, April 5-9, Boston, MA, 1994,
- <sup>14</sup> Issues in UHMWPE February 1995, Westlake Plastics Co., Medical Plastics Division, Lenni, PA 1995



1115 Windfield Way, Suite 100  
El Dorado Hills, Ca 95762  
☎ 916-355-7100, 📠 916-355-7190  
✉ info@consensusortho.com  
🌐 consensusortho.com